



**US**

## **Operator's manual**

Please read the operator's manual carefully and make sure you understand the instructions before using the machine.

**FR**

## **Manuel d'utilisation**

Lire attentivement et bien assimiler le manuel d'utilisation avant d'utiliser la machine.

**ES**

## **Manual de instrucciones**

Lea detenidamente el manual de instrucciones y asegúrese de entender su contenido antes de utilizar la máquina.

**TS 60**

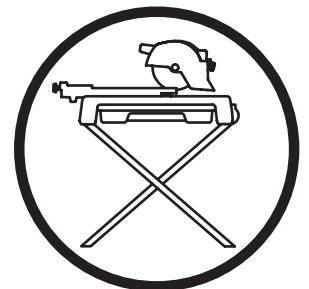

**US FR ES**

# KEY TO SYMBOLS

## Symbols on the machine

WARNING! The machine can be a dangerous tool if used incorrectly or carelessly, which can cause serious or fatal injury to the operator or others.

Please read the operator's manual carefully and make sure you understand the instructions before using the machine.

Use hearing protection

Always wear protective goggles.

Use a breathing mask.

Warning! Never cut without using the blade guard.

Warning! Keep your hands and feet away from the blade.

**Environmental marking.** Symbols on the product or its packaging indicate that this product cannot be handled as domestic waste. It must instead be submitted to an appropriate recycling station for the recovery of electrical and electronic equipment.

By ensuring that this product is taken care of correctly, you can help to counteract the potential negative impact on the environment and people that can otherwise result through the incorrect waste management of this product.

For more detailed information about recycling this product, contact your municipality, your domestic waste service or the shop from where you purchased the product.

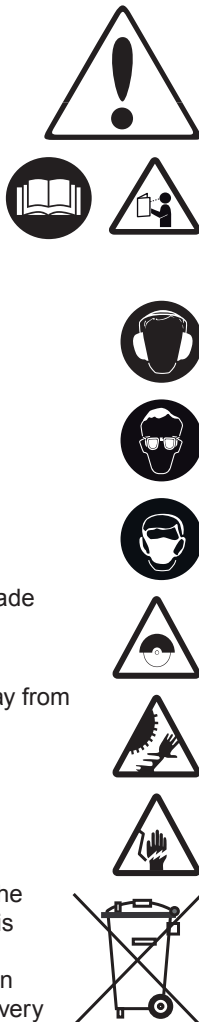

Other symbols/decals on the machine refer to special certification requirements for certain markets.

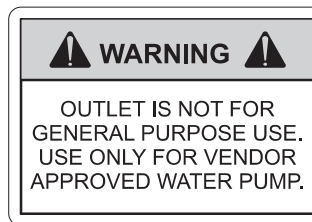
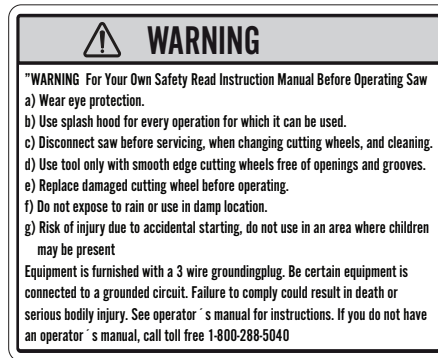

## Explanation of warning levels

The warnings are graded in three levels.

### WARNING!

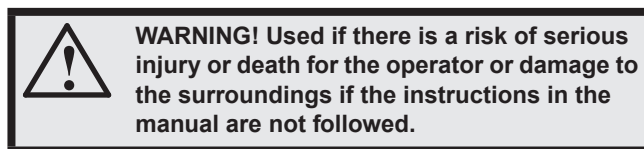

### CAUTION!

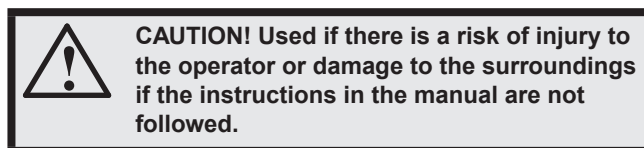

### NOTICE!

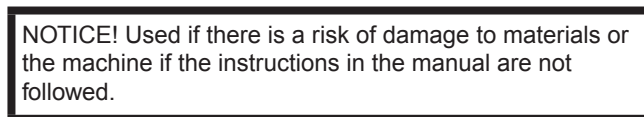

# CONTENTS

## Contents

### KEY TO SYMBOLS

Symbols on the machine .....	2
Explanation of warning levels .....	2

### CONTENTS

Contents .....	3
----------------	---

### PRESENTATION

Dear customer! .....	4
Features .....	4

### PRESENTATION

What is what on the machine? .....	5
------------------------------------	---

### MACHINE'S SAFETY EQUIPMENT

General .....	6
---------------	---

### BLADES

General .....	7
Transport and storage .....	7

### ASSEMBLING AND ADJUSTMENTS

General .....	8
Depth stop adjustment .....	10
Mitre cutting .....	10
Level the saw .....	10
Guide rollers .....	10
Fit the blade .....	11

### OPERATING

Protective equipment .....	12
General safety precautions .....	12
Electrical safety .....	13
Work safety .....	14
Transport and storage .....	14

### STARTING AND STOPPING

Before starting .....	16
Starting .....	16
Stopping .....	16

### MAINTENANCE

General .....	17
Daily maintenance .....	17
Replacing the carbon brushes .....	17
Water pump .....	17
Water drain .....	17
Repairs .....	17

### TECHNICAL DATA

Technical data .....	18
Recommended extension .....	18

### US WARRANTY STATEMENT

WARRANTY POLICY .....	19
EQUIPMENT .....	19

### WIRING DIAGRAM

## Dear customer!

Thank you for choosing a Husqvarna product!

It is our wish that you will be satisfied with your product and that it will be your companion for a long time. A purchase of one of our products gives you access to professional help with repairs and services. If the retailer who sells your machine is not one of our authorised dealers, ask him for the address of your nearest service workshop.

This operator's manual is a valuable document. Make sure it is always at hand at the work place. By following its content (using, service, maintenance etc) the life span and the second-hand value of the machine can be extended. If you ever lend or sell this machine, make sure that the borrower or buyer gets the operator's manual, so they will also know how to properly maintain and use it.

## More than 300 years of innovation

Husqvarna AB is a Swedish company based on a tradition that dates back to 1689, when the Swedish King Charles XI ordered the construction of a factory for production of muskets. At that time, the foundation was already laid for the engineering skills behind the development of some of the world's leading products in areas such as hunting weapons, bicycles, motorcycles, domestic appliances, sewing machines and outdoor products.

Husqvarna is the global leader in outdoor power products for forestry, park maintenance and lawn and garden care, as well as cutting equipment and diamond tools for the construction and stone industries.

## User responsibility

It is the owner's/employer's responsibility that the operator has sufficient knowledge about how to use the machine safely. Supervisors and operators must have read and understood the Operator's Manual. They must be aware of:

- The machine's safety instructions.
- The machine's range of applications and limitations.
- How the machine is to be used and maintained.

National legislation could regulate the use of this machine. Find out what legislation is applicable in the place where you work before you start using the machine.

## The manufacturer's reservation

All information and all data in the Operator's Manual were applicable at the time the Operator's Manual was sent to print.

Husqvarna AB has a policy of continuous product development and therefore reserves the right to modify the design and appearance of products without prior notice.

For customer assistance, contact us at our website:  
[www.usa.husqvarna.com](http://www.usa.husqvarna.com)

## Features

Values such as high performance, reliability, innovative technology, advanced technical solutions and environmental considerations distinguish Husqvarna's products.

Some of the unique features of your product are described below.

## Softstart™

Softstart™ is an electronic current limiter which provides a softer start.

## Elgard™

Elgard™ is an electronic overload protection that protects the motor. The protection spares the machine and extends its service life. With the help of Elgard™, the machine indicates when it approaches maximum load.

## Lightweight and mobile design

The machine is lightweight and compact. The carry handles on the frame and transportation wheels make the machine easy to carry and move. The integrated wheels allow the saw frame to be pulled like a roller bag.

The stand is foldable and height adjustable.

## Jet stream containment system with slurry protection

The patented Jet stream system provides the conveyor cart and the blade with water in a closed system.

The slurry sinks to the bottom and only surface water reaches the pump, which is placed in a protected compartment of the water tray.

The conveyor cart is continuously supplied with water. The water supply to the blade is adjustable.

## Flexible cutting

Flexible plunge cutting and mitre cutting up to 45°.

Enables cutting of 500x500 mm (20"x20") tile diagonally giving a cutting length of 718 mm (28").

## Functional conveyor cart and side table

The conveyor cart is extra long for better support when cutting. The side table is removable.

## Large blade flange

The large size blade flange Ø 82 mm (3") provides a large and good support surface for the blade.

# PRESENTATION

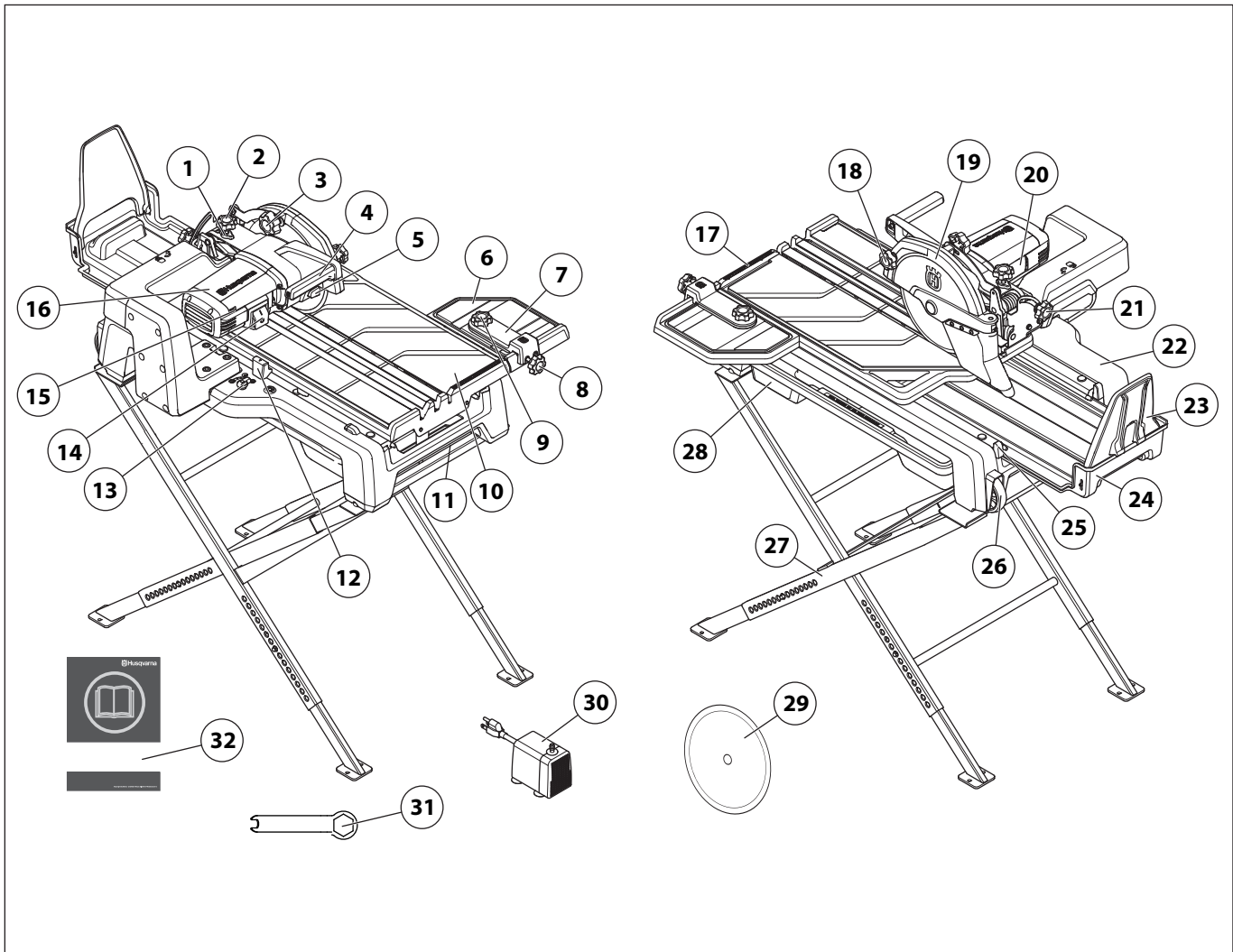

## What is what on the machine?

- |    |  |    |                             |
|----|--|----|-----------------------------|
| 1  | Locking nut, depth stop adjustment           | 17 | Adjustable ruler            |
| 2  | Knob, depth stop adjustment                  | 18 | Locking knob, blade guard   |
| 3  | Locking knob, depth adjustment               | 19 | Blade Guard                 |
| 4  | Handle, cutting arm                          | 20 | Product and type plate      |
| 5  | Button, locking blade shaft                  | 21 | Locking knob, miter cutting |
| 6  | Side table                                   | 22 | Frame                       |
| 7  | Cutting guide                                | 23 | Splash guard                |
| 8  | Locking knob, cutting guide                  | 24 | Slurry collector tray       |
| 9  | Locking knob, angle adjustment cutting guide | 25 | Cart stop                   |
| 10 | Conveyor cart                                | 26 | Transport wheels            |
| 11 | Water recovery tray                          | 27 | Folding stand legs          |
| 12 | Locking knob, conveyor cart                  | 28 | Water tray                  |
| 13 | Water knob, water to blade ON/OFF            | 29 | Blade - Superlok GP (10")   |
| 14 | Power switch                                 | 30 | Water pump                  |
| 15 | Load indicator, Elgard™                      | 31 | Spanner                     |
| 16 | Electric motor                               | 32 | Operator's manual           |

# MACHINE'S SAFETY EQUIPMENT

## General



**WARNING! Never use a machine that has faulty safety equipment!**

WARNING! If your machine fails any of these checks contact your service agent to get it repaired.

This section describes the machine's safety equipment, its purpose, and how checks and maintenance should be carried out to ensure that it operates correctly.

## Blade guard



**WARNING! Never use the machine without a guard nor with a defective guard. Always check that the guard is correctly fitted before starting the machine.**

**It is not permitted to expose the blade more than 180 degrees without protection.**

The blade guard is designed to prevent parts of the blade or cutting fragments from being thrown towards the user.

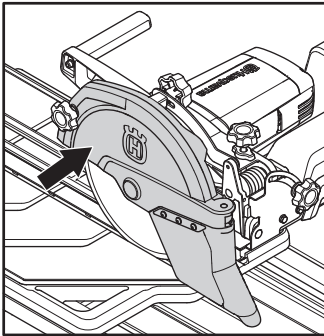

## Checking the blade guard



**WARNING! Shut down the machine and disconnect the power plug.**

- Check that the guard over the blade is not cracked or damaged in any other way. Replace when damaged.

## Power switch

The power switch should be used to start and stop the machine.

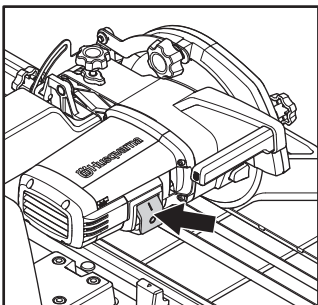

## Checking the power switch

- Flip the power switch up to start the machine.

- Flip the power switch down to stop the machine. Check that the motor and the blade stop. Make sure that the cutting blade can rotate freely until it is completely stopped.

A defective power switch should be replaced by an authorized service workshop.

## Locking knob, conveyor cart

The locking knob is used to lock the conveyor cart in place when in transit.

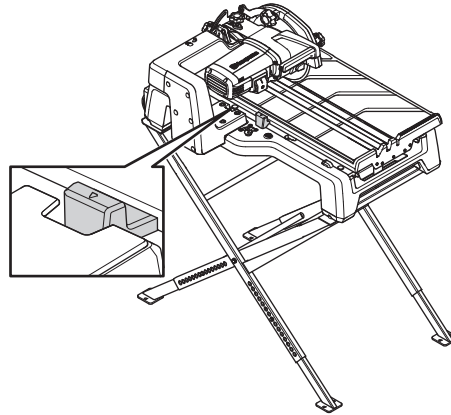

## Water pump



**WARNING! Submersible water pump. Do not run dry. For household use only. Must maintain grounding properly. Risk of electric shock. This pump has not been investigated for use in swimming pool areas.**

# BLADES

## General



**WARNING! Blades can break and cause serious injuries to the user. Diamond blades get very hot when used. An overheated blade is a result of improper use, and may cause deformation of the blade, resulting in damage and injuries.**

- Do not use an overheated blade.
- Make sure that the correct bushing is used for the cutting blade to be fitted on the machine. See the instructions under the heading Assembling the cutting blade.
- The blades should be marked with the same or a higher speed than that stated on the machine's rating plate. Never use a blade with a lower speed rating than that of the machine.
- When using diamond blades make sure that it rotates in the direction indicated by the arrow on the blade.

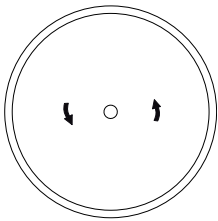

- Diamond blades consist of a steel core provided with segments or a continuous rim containing industrial diamonds.

## Suitable blades

- 8" or 10" continuous rim blade. 8" profile wheel.

## Blades for different materials



**WARNING! Never use a blade for any other materials than that it was intended for.**

**Cutting plastics with a diamond blade can cause kickback when the material melts due to the heat produced when cutting and sticks to the blade. Never cut plastic materials with a diamond blade!**

- Blade selection should be made according to the material being cut. Ask your dealer for help in choosing the right product.

## Blade vibrations

- The blade can become out of round and vibrate if a too high feed pressure is used.
- A lower feed pressure can stop the vibration. Otherwise replace the blade.

## Sharpening diamond blades

- Always use a sharp diamond blade.

- Diamond blades can become dull when the wrong feeding pressure is used or when cutting certain materials such as heavily reinforced concrete. Working with a blunt diamond blade causes overheating, which can result in the diamond segments coming loose.
- Sharpen the blade by cutting in a soft material such as sandstone or brick.

## Transport and storage

- Remove the blade before transportation or storage of the machine.
- Store the blade in a dry place.
- Inspect new blades for transport or storage damage.

# ASSEMBLING AND ADJUSTMENTS

## General

- Mount the frame legs together using the bolts. The legs can be folded together for easier transport.

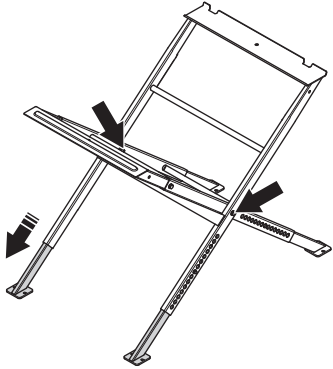

- Adjust the working height by releasing the spring loaded quick connector and slide the inner tube to wished height.
- Lift the saw on the stand. The slot on the saw must be aligned with the groove on the stand.

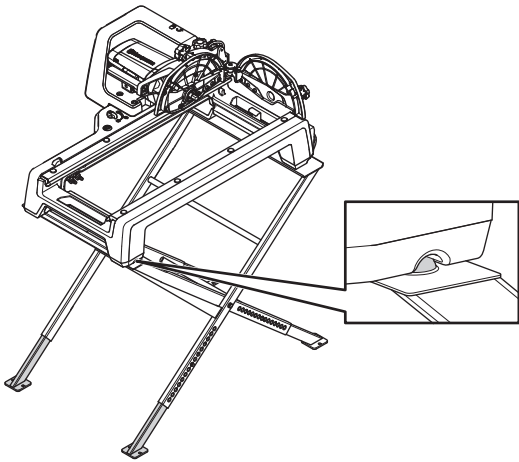

Use the two clamps, one on each side, to fasten the frame on to the stand.

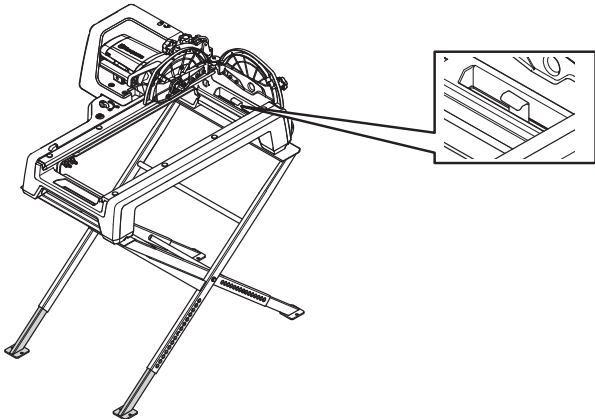

- Pull out the locking knob on the conveyor cart.

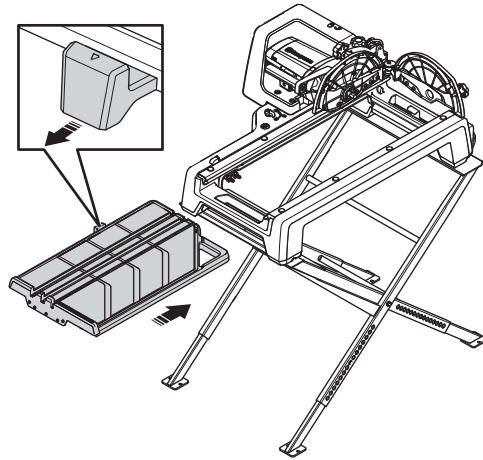

- Slide the conveyor cart onto the frame. Make sure that the support rollers sit correctly in the slot.
- When the locking knob past the lug on the frame, push the locking knob in to allow the conveyor cart to slide all the way in.
- Fit the side table using the supplied screws.

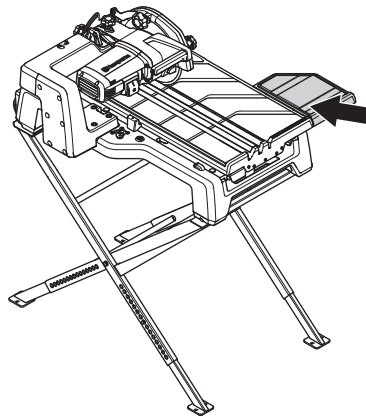

If the side table is not in level with the conveyor cart it may need adjustment. Adjust using the screws.

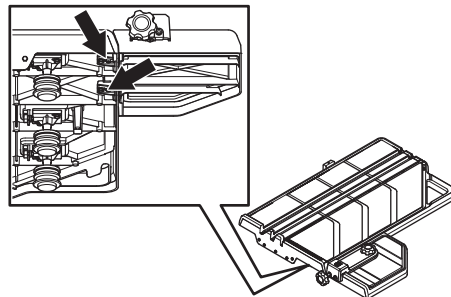



# ASSEMBLING AND ADJUSTMENTS

- Screw the cutting guide onto the conveyor cart. The guide can be folded outwards for angled cuts. Use the angle markings on the cutting guide to set the correct angle.

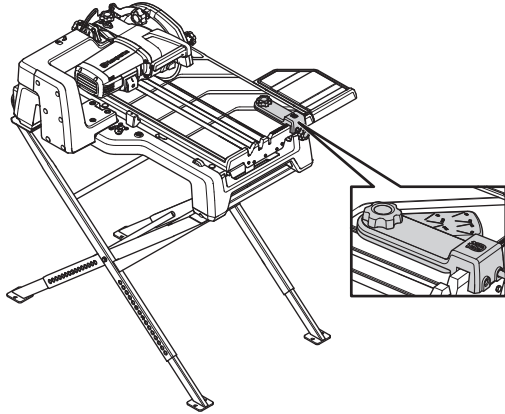

- Assemble the water recovery tray. Make sure that the plastic hook grips the metal bar under the cart.

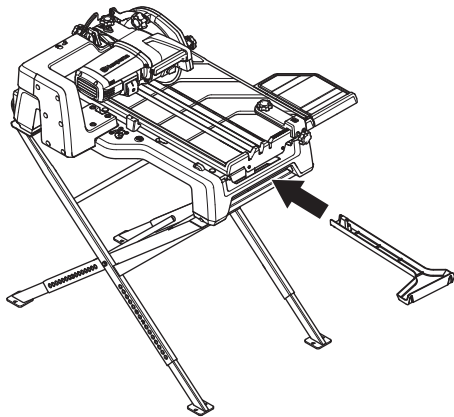

- Connect the water hose (2) and the water pump (1) to the connectors on the frame.

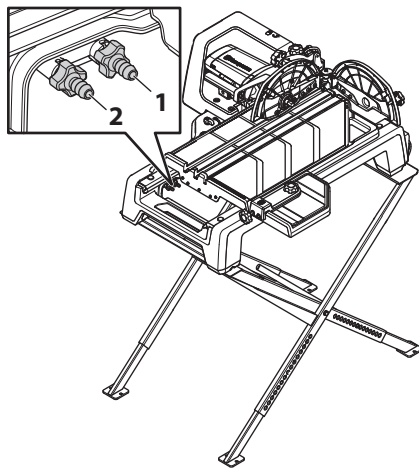

- Place the water pump in the water tray. The pump compartment should face towards the working position. Slide in the water tray.

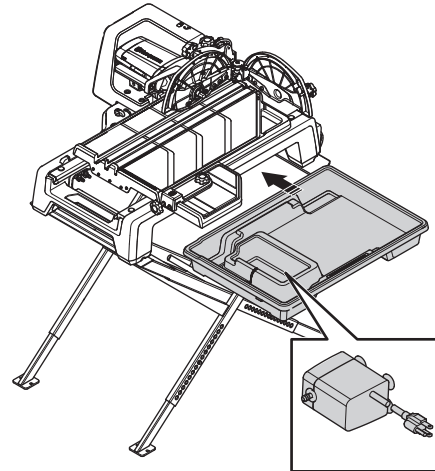

- Fill the water tray with water up to the marked level.

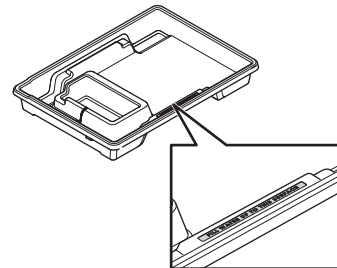

- Slide out the slurry collector tray and flip up the slurry collector tray extension.

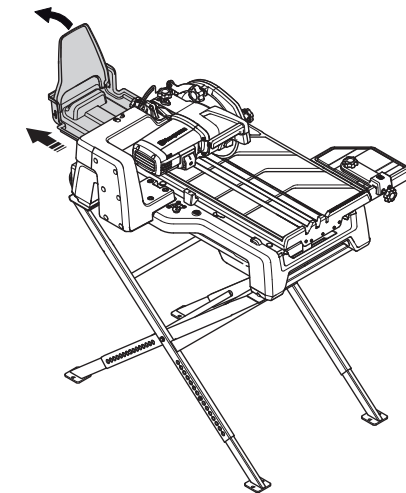

- With a push, the slurry collector tray can be locked in its inner position.

# ASSEMBLING AND ADJUSTMENTS

- Connect the power cable for the water pump to the plug on the machine.

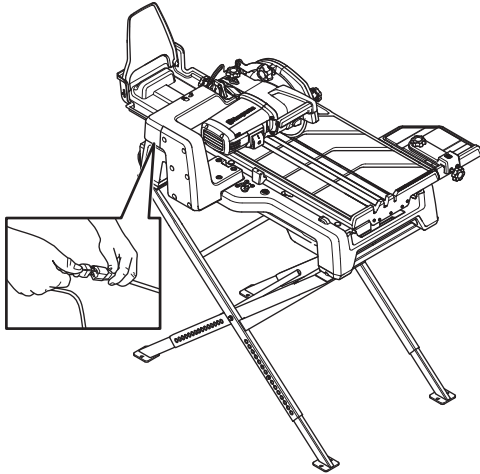

- Make sure the water level is maintained at this level when cutting.

## Depth stop adjustment

Set the depth stop so that the blade gets maximum cutting depth without cutting into the cart. This allows the stream of water in the cart to be picked up by the blade and distributed as the working piece is cut.

The depth stop should be adjusted when switching to other blade sizes.

- Loosen the locking knob for depth setting (1) and lower the cutting arm.

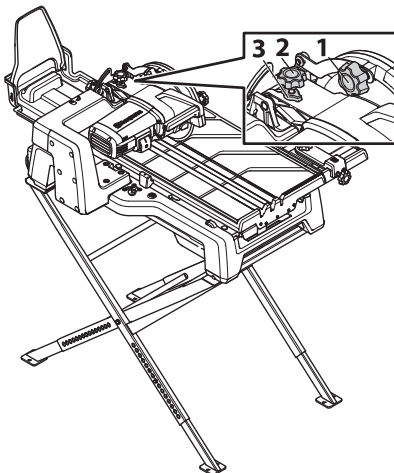

- Loosen the lock nut (3).
- Loosen the depth stop adjustment knob (2).
- Push down the cutting arm until the blade hits the bottom of the slot in the cart.
- Hold down the cutting arm in this position.
- Screw the depth stop adjustment knob (2) down until it touches the bracket underneath to set the depth of the blade. Turn another turn to raise the head from the cart slightly.
- Tighten the locking nut (3).
- Tighten the locking knob for depth adjustment (1) with the cutting arm still pushed down to its lowest position.

- Check the position of the blade by moving the conveyor cart to its forward and rear end position. The blade should never hit the cart.

## Mitre cutting

The cutting arm can pivot up to 45° degrees. There is a marking at 22.5°.

- Loosen the lock knob for miter cutting and set the required angle.

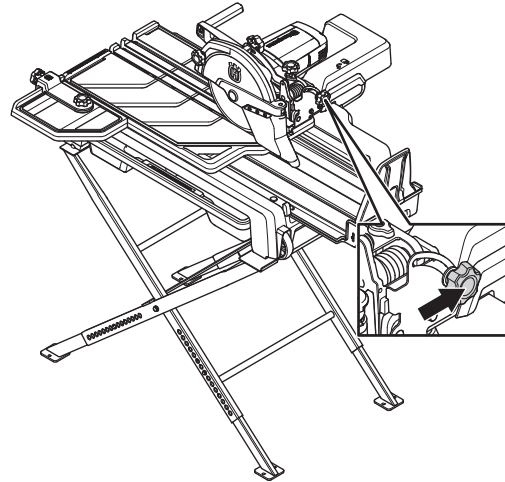

- Lock the knob.

## Level the saw

For the water system to perform as intended the machine is not allowed to tilt more than 1,5° length wise and 3° side to side.

- Position the machine on flat ground. Adjust the frame legs and use shimming material if needed to level the machine. Use the bubble to check the inclination.

## Guide rollers

### General

If the conveyor cart doesn't run smoothly or if the cart is rocking the rollers may need to be adjusted.

- Check that wheels and guides are clean.
- Check that the roller shafts are properly tightened.

### Adjusting the guide rollers

- Place the cart in its middle position and lock it in place with the locking knob.
- Rotate the rollers by hand and check that all rollers can rotate freely using the same force. If not, the rollers may need to be realigned.

# ASSEMBLING AND ADJUSTMENTS

- Loose all adjustable brackets.

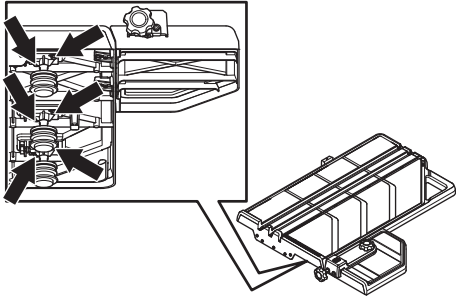

- Rock the cart back and forth to make sure that all brackets are loose. Let the force of the springs push all rollers towards the guides.
- Lock all rollers by tightening the screws on the roller brackets.

## Fit the blade

- Loosen the lock knob. Open the blade guard.

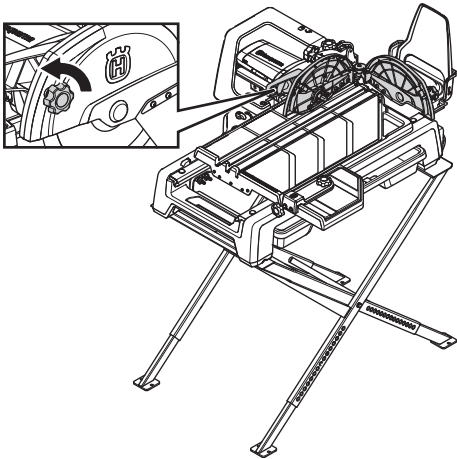

- Hold down the button for locking the blade shaft.

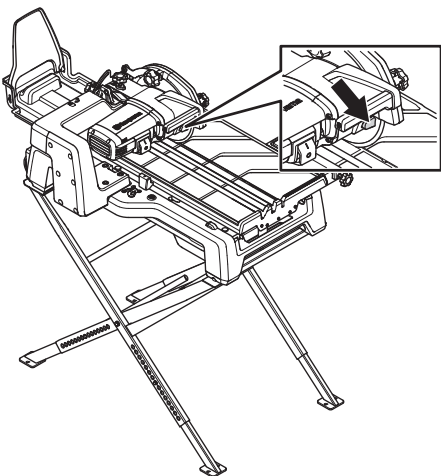

- Remove the nut. Remove the blade flange.
- Check that the blade, blade flange and blade shaft are undamaged. Clean the contact surfaces of the blade and the blade flange.
- Make sure that the blade will rotate in the direction indicated by the arrow on the blade.

- When mounting the blade pull out the spray nozzle and move it from or towards the centre axle depending on the size of the blade(10" or 8" blades).
- When mounting the blade pull out the spray nozzle and move it from or towards the centre axle depending on the size of the blade(10" or 8" blades).

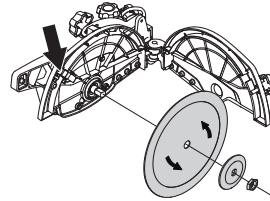

- Fit the blade, blade flange and nut.

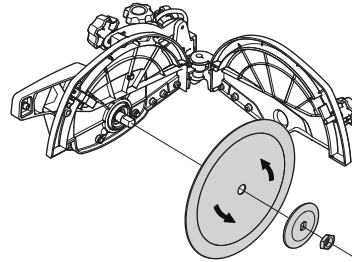

- Close the blade guard. Tighten the locking knob.

# OPERATING

## Protective equipment

### General

Do not use the machine unless you are able to call for help in the event of an accident.

### Personal protective equipment

You must use approved personal protective equipment whenever you use the machine. Personal protective equipment cannot eliminate the risk of injury but it will reduce the degree of injury if an accident does happen. Ask your dealer for help in choosing the right equipment.



**WARNING!** The use of products such as cutters, grinders, drills, that sand or form material can generate dust and vapours which may contain hazardous chemicals. Check the nature of the material you intend to process and use an appropriate breathing mask.



**WARNING!** Long-term exposure to noise can result in permanent hearing impairment. So always use approved hearing protection.

Listen out for warning signals or shouts when you are wearing hearing protection. Always remove your hearing protection as soon as the motor stops.



**WARNING!** There is always a risk of crush injuries when working with products containing moving parts. Wear protective gloves to avoid body injuries.

Always wear:

- Hearing protection
- Approved eye protection. If you use a face shield then you must also wear approved protective goggles. Approved protective goggles must comply with standard ANSI Z87.1 in the USA or EN 166 in EU countries. Visors must comply with standard EN 1731.
- Breathing mask
- Protective gloves.

Generally clothes should be close-fitting without restricting your freedom of movement. Be careful as clothing, long hair, and jewellery can get caught in moving parts.

### Other protective equipment



**WARNING!** Sparks may appear and start a fire when you work with the machine. Always keep fire fighting equipment handy.

- Fire fighting equipment
- Always have a first aid kit nearby.

## General safety precautions

This section describes basic safety directions for using the machine. This information is never a substitute for professional skills and experience.

- Please read the operator's manual carefully and make sure you understand the instructions before using the machine. Save all warnings and instructions for future reference.
- Keep in mind that the operator is responsible for accidents or hazards occurring to other people or their property.
- All operators shall be trained in the use of the machine. The owner is responsible for ensuring that the operators receive training.
- The machine must be kept clean. Signs and stickers must be fully legible.



**WARNING!** The machine can be a dangerous tool if used incorrectly or carelessly, which can cause serious or fatal injury to the operator or others.

Never allow children or other persons not trained in the use of the machine to use or service it. Never allow anyone else to use the machine without first ensuring that they have understood the contents of the operator's manual.

Never use the machine if you are fatigued, while under the influence of alcohol or drugs, medication or anything that could affect your vision, alertness, coordination or judgement.



**WARNING!** Unauthorized modifications and/or accessories may lead to serious injury or death to the user or others.

Do not modify this product or use it if it appears to have been modified by others.

Never use a machine that is faulty. Carry out the checks, maintenance and service instructions described in this manual. Some maintenance and service measures must be carried out by trained and qualified specialists. See instructions under the heading Maintenance.

Always use genuine accessories. Contact your dealer for more information.

### Always use common sense

It is not possible to cover every conceivable situation you can face. Always exercise care and use your common sense. If you get into a situation where you feel unsafe, stop and seek expert advice. Contact your dealer, service agent or an experienced user. Do not attempt any task that you feel unsure of!

# OPERATING

## Dust warning



**WARNING!** Cutting, especially when DRY cutting, generates dust that comes from the material being cut, which frequently contains silica. Silica is a basic component of sand, quartz, brick clay, granite and numerous other minerals and rocks. Exposure to excessive amount of such dust can cause:

Respiratory disease (affecting your ability to breath), including chronic bronchitis, silicosis and pulmonary fibrosis from exposure to silica. These diseases may be fatal;

Skin irritation and rash.

Cancer according to NTP\* and IARC\* \*/ National Toxicology Program, International Agency for Research on Cancer

Take precautionary steps:

Avoid inhalation of and skin contact with dust, mist and fumes.

Wet cut when feasible, to minimize dust.

Wear and ensure that all bystanders wear appropriate respiratory protection such as dust masks designed to filter out microscopic particles. (See OSHA 29 CFR Part 1910.1200)

## California Prop 65 Warning



**WARNING!** Use of this product can cause exposure to materials known to the State of California to cause cancer and/or birth defects or other reproductive harm.

## Electrical safety



**WARNING!** There is always a risk of shocks from electrically powered machines. Avoid unfavourable weather conditions and body contact with lightning conductors and metal objects. Always follow the instructions in the Operator's manual to avoid damage.

Never connect the machine to a outlet if plug or cord is damaged.



**WARNING!** When cleaning the machine make sure to avoid water entering the electrical system and the motor unit. Water can cause damage to the machine or short circuit.

- Check that the mains voltage corresponds with that stated on the rating plate on the machine.
- Inspection and/or maintenance should be carried out with the motor switched off and the plug disconnected.

- Always shut down the machine before disconnecting the power plug.
- Never drag the machine by means of the cord and never pull out the plug by pulling the cord. Hold the plug to disconnect the power cord.
- Never use the machine if any cable or plug is damaged, but hand it in to an authorized service workshop for repair.
- Always connect the machine through an ground fault circuit interrupter with personal protection, i.e. an ground fault circuit interrupter that trips at an ground fault of 30 mA.
- Prevent unintentional starting of the motor. Ensure the power switch is in the OFF-position before connecting the machine to a power source.

## Grounding instructions



**WARNING!** Improper connection can result in the risk of electric shock. Contact a qualified electrician if in doubt as to whether the appliance is properly grounded.

Do not modify the plug. If it will not fit the outlet have a proper outlet installed by a qualified electrician. Make sure local regulations and ordinances are followed.

If the grounding instructions are not fully understood contact a qualified electrician.

- The machine is equipped with a grounded cord and plug and should always be connected to a grounded outlet. This reduces the risk of electric shock in the event of malfunction.
- A temporary adapter (1) may be used to connect this plug to a 2-pole receptacle if a properly grounded outlet is not available. The ear lug (2) extending from the adapter must be connected to a permanent ground such as a properly grounded outlet box.

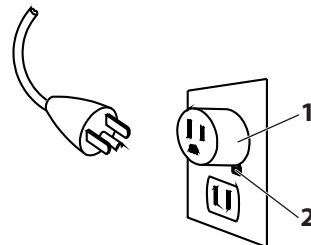

The temporary adapter should be used only until a properly grounded outlet can be installed by a qualified electrician.

## Extension cords and cables

- The marking on the extension cable must be the same or higher than the value stated on the machine's rating plate.
- Use grounded extension cables.
- When operating a power tool outdoors, use an extension cord suitable for outdoor use. Use of cord suitable for outdoor use reduces the risk of electric shock.
- Keep the connection to the extension cord dry and off the ground.

# OPERATING

- Keep cable away from heat, oil, sharp edges or moving parts. Damaged or entangled cable increase the risk of electric shock.
- Check that the cord and extension cord are intact and in good condition. Never use the machine if any cable or plug is damaged, but hand it in to an authorized service workshop for repair.
- To avoid overheating do not use the extension cord while it is rolled up.
- When using an extension cable, use only certified extension cables with sufficient reach. For more information, see "Recommended cable dimensions" in the "Technical data" section.

## Work safety

### Work area safety

- Keep work area clean and well lit. Cluttered or dark areas invite accidents.
- People and animals can distract you causing you to lose control of the machine. For this reason, always remain concentrated and focused on the task.
- Do not use the machine in bad weather, such as dense fog, heavy rain, strong wind, intense cold, etc.
- Never start to work with the machine before the working area is clear and you have a firm foothold.
- Take the risk of spark formation into account when working in flammable environments.

### Personal safety

- Never use the machine if you are fatigued, while under the influence of alcohol or drugs, medication or anything that could affect your vision, alertness, coordination or judgement.
- Check that no tools or other objects have been left lying on the machine.
- Never allow anyone else to use the machine without proper training.
- Always shut off the machine during longer work breaks.
- Never work alone, always ensure there is another person close at hand.
- Learn how to use the machine and its controls safely and learn to how to stop quickly. Also learn to recognize the safety decals.
- Do not overreach. Keep proper footing and balance at all times.
- Never stand on the machine.

### Use and care

- This machine is designed and intended for cutting tile and stone. All other use is improper. All other use is improper.
- Experience is very important when running the machine. A skilled worker is highly recommended.
- The machine is intended for use in industrial applications by experienced operators.

- Check that the machine is assembled correctly and do not show any signs of damage.
- Always perform daily maintenance before starting the engine. See instructions in the section "Maintenance".
- Do not overload the machine. Overloading can damage the machine.
- The blade shall be intended for the material to be cut.
- If you are uncertain of what blade to use contact your local service dealer.
- Keep tools sharp and clean in order to enable safer work.
- Keep all parts in good working order and ensure that all fixtures are properly tightened. Replace all worn or damaged decals.
- Never leave the machine unsupervised with the motor running.
- Secure the work piece using a clamp or a vise when possible. It is safer than using your hand and it frees both hands to operate the machine.
- Feed the work piece against the rotation of the blade only!
- Observe care when lifting. You are handling heavy parts, which implies the risk of pinch injuries or other injuries.

### Water cooling to the blade

- Water cooling through the blade guard should always be used when miter cutting and when diagonal cutting 500 mm (20") tile. The cut is longer than the cart and at the start of the cut, the blade will not pick up any water from the slot in the cart.
- Turn the water knob slightly to redirect water to the blade.
- When reaching the slot in the cart, the water to the blade can be shut off in order to keep the area as clean as possible.

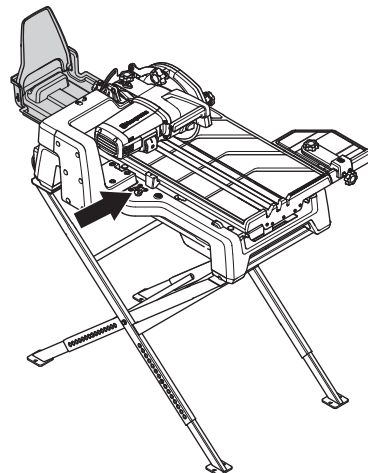

### Transport and storage

Stop the motor and disconnect the power cable before lifting or moving the machine.

- Secure the equipment during transportation in order to avoid transport damage and accidents.

Ensure that the conveyor cart is locked and that the extension slide is locked in its inner position.

# OPERATING

- Store the equipment in a lockable area so that it is out of reach of children and unauthorized persons.
- For transport and storage of Blades, see the section "Blades".
- Lift the machine at the short ends.

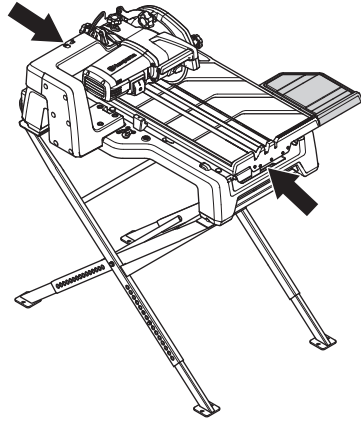

# STARTING AND STOPPING

## Before starting



**WARNING!** Please read the operator's manual carefully and make sure you understand the instructions before using the machine.

**Wear personal protective equipment. See instructions under the heading "Personal protective equipment".**

**Make sure no unauthorised persons are in the working area, otherwise there is a risk of serious personal injury.**

**Prevent unintentional starting of the motor. Ensure the power switch is in the OFF-position before connecting the machine to a power source.**

- Check that the machine is assembled correctly and do not show any signs of damage. See instructions in the section "Assembling and adjustments".
- Perform daily maintenance. See instructions in the section "Maintenance".

## Starting

- Flip the power switch up to start the machine.

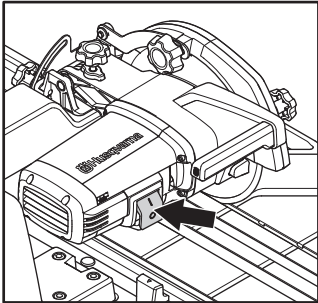

- The water pump starts automatically when the machine is started.
- Wait a few seconds for the water slots in the cart to be filled with water before starting to cut.

## Stopping

- Flip the power switch down to stop the machine.
- Make sure that the cutting blade can rotate freely until it is completely stopped.



## General



**WARNING!** The user must only carry out the maintenance and service work described in this manual. More extensive work must be carried out by an authorized service workshop.

To prevent accidental starting, the steps described in this chapter must be performed with the motor off and the power cable removed from the socket, if not otherwise stated.

Wear personal protective equipment. See instructions under the heading "Personal protective equipment".

The life span of the machine can be reduced and the risk of accidents can increase if machine maintenance is not carried out correctly and if service and/or repairs are not carried out professionally. If you need further information please contact your nearest servicing dealer.

## Daily maintenance

- Check that the machine's safety equipment is undamaged. See instructions in the section "Machine's safety equipment".
- Clean the outside of the machine. Do not use a high pressure washer to clean the saw.



**WARNING!** Never clean motor and electric parts with water.

**NOTICE!** Clean the machine properly to prevent debris and small pieces of tile to enter and cause damage to the water system. If any back flushing water from the cart is flooding over the collector tray under the cart, remove the collector tray and clean it out. Reattach the collector tray.

## Replacing the carbon brushes

The carbon brushes must be removed and checked regularly. Weekly if the machine is used daily or at longer intervals if the machine is used more seldom.

- Loosen the bolts holding the protective hood and then lift off the cover.

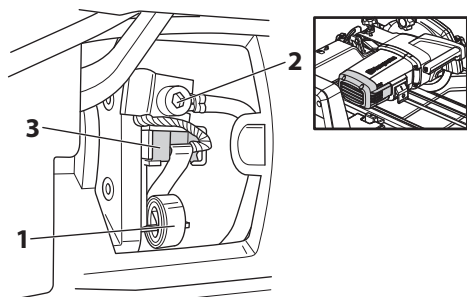

- Loosen the screw (2).

- Lift the brush retainer spring to one side (1).
- Pull out the coal brush from the holder (3).
- Fit the new carbon brush. Make sure to fit the carbon brush the right way and that it slides easily into the brush holder. If the carbon brush is fitted the wrong way, it can get stuck.
- Put the brush holder spring back into place.
- Insert the carbon brush connection under the screw.
- Repeat the procedure with the other carbon brush.
- Assemble the protective cover.

## Water pump

Do the following if the water pump stops pumping water.

- Stop cutting.
- Shut down the machine and disconnect the power plug.
- Remove the water pump.

## Clean the water pump

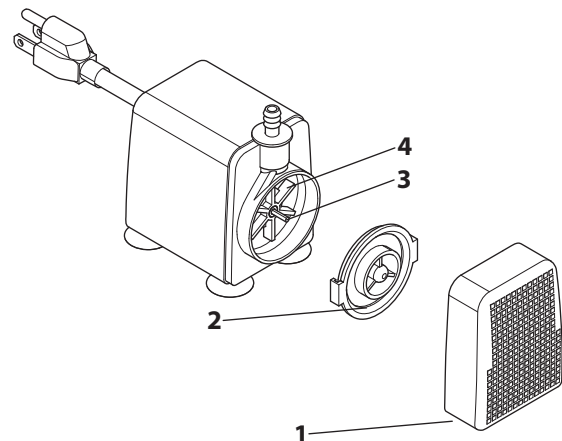

- Remove the water intake lid (1).
- Twist the impeller cover (2) and pull out.
- Pull out the impeller (4) and shaft (3) and clean the parts including the housing.

A cloth may be used to remove iron particles that might adhere to the magnetic rotor shaft.

## Water drain

Clean the water recovery tray after every use.

- Stop the cutting.
- Lift the water recovery tray and pull to release the back of the water recovery tray.
- Lift up and release the plastic hook from under the cart.
- Clean the water recovery tray and put it back.

## Repairs

All types of repairs may only be carried out by authorised repairmen. This is so that the operators are not exposed to great risks.

# TECHNICAL DATA

## Technical data

Power, kW (hp)	1,7 (2.3)
Voltage, V	120
Phases	1
Frequency, Hz	50-60
Speed, rpm	3000
Water pump, V	120
Water pump frequency, Hz	60
Water pump, A	0.48
Water pump Hmax (m)	2,8
Water pump Qmax (l/h)	1350
Blade size - max, mm (inches)	254 (10)
Saw depth - max, mm (inch)	78 (3)
Cutting depth at 45° - max, mm (inch)	45 (1.8)
Cutting length - max, mm (inch)	726 (28 5/8)
Arbor size, mm (inch)	16 (5/8)
Angle cutting	45°, 22,5°
Water tank, l (gal)	12,4 (3.3)
Weight, kg (lb)	36 (79)
Weight - loaded, kg (lb)	60 (132,6)
Size, (LxWxH), mm (inch)	932x700x468 (37x28x18)
Dimensions - loaded (Lx W x H), mm (inch)	1007x565x745 (40x22x29)

## Recommended extension



Good motor performance depends on proper voltage. Extension cords that are too long and/or too small in wire gauge reduce the voltage to the motor under load. Use extension cords no smaller than indicated below.

Cord length 0-25 feet 25-50 feet  
120 V  
14-17 A 12 AWG 10 AWG

# US WARRANTY STATEMENT

---

## WARRANTY POLICY

All warranty claims will be determined after inspection at a designated facility. A Returned Goods Authorization is required for all warranty claims. Contact Husqvarna Customer Service Department at 800-845-1312 for an RGA. The customer must prepay the freight and absorb any labor expense required to return or replace a product submitted for warranty consideration. Husqvarna will pay return shipping expenses for repaired or approved replacement products.

## EQUIPMENT

Equipment manufactured by Husqvarna is warranted to be free from manufacturing defects in normal service for a period of two (2) years from date of purchase by the original consumer purchaser. **Component manufacturers offer separate warranty periods. Call Technical Services at 800-288-5040 for complete information.**

Our obligation under this warranty is expressly limited to the replacement or repair at Husqvarna Construction Products North America, Olathe, Kansas 66061, or at a service facility designated by us, of such part or parts as inspection shall disclose to have been defective.

This warranty does not apply to defects caused by damage, unreasonable use, faulty repairs made by others than an approved Husqvarna servicing dealer, or defects caused by failure to provide reasonable maintenance, while in the possession of the consumer. Further, the warranty is void if the product, or any of its components, are altered or modified by the consumer purchaser, or if the product is used in an inappropriate manner or with tools not recommended by the manufacturer.

**Exceptions:** Drill motors - 3 months, Wall saws - 1 year, Power cutters - 3 months, DM230 - 1 year, DM225 - 3 months, Gyro systems - 1 year, CD40 system - 1 year, DS160 C - 1 year, Smart box - 1 year, CS2515 - 1 year, PP455 E - 1 year, PP345 E - 1 year, HP40 - 1 year.

**Wear items:** Filters, spark plugs, bearings\*, belts, wheels\*\* and wear pads.

\*Except IntelliSeal™ system. \*\*Except delamination.

# WIRING DIAGRAM

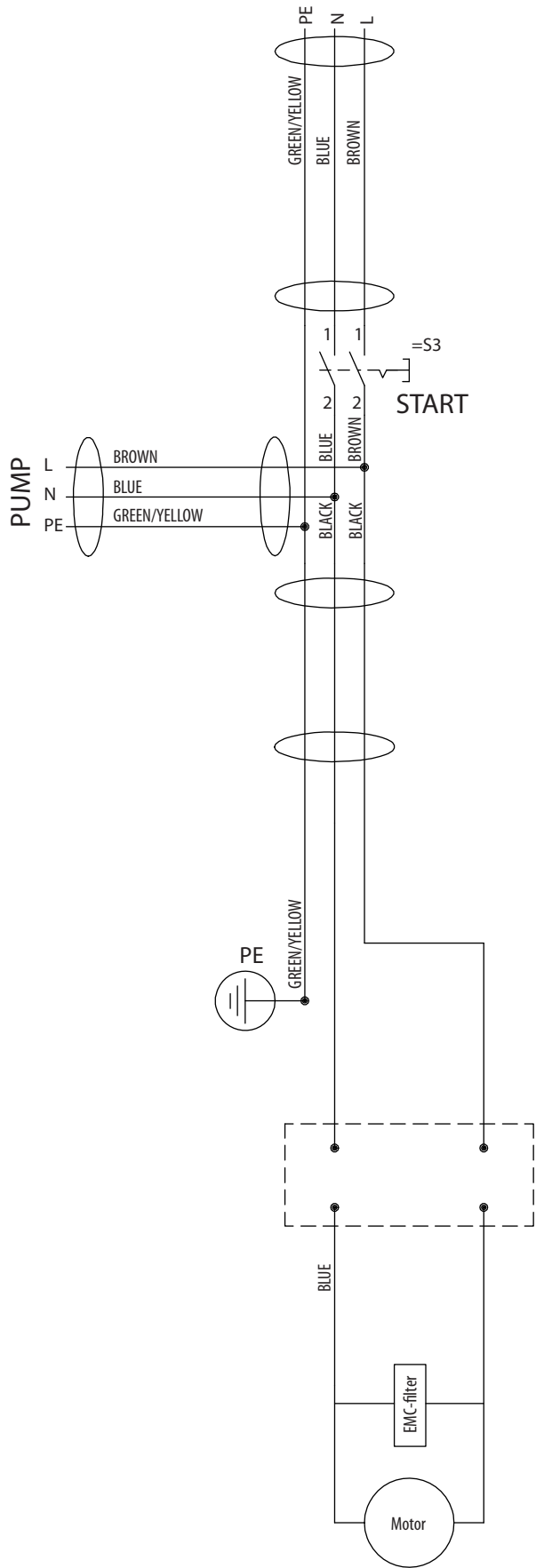

# EXPLICATION DES SYMBOLES

## Symboles sur la machine

AVERTISSEMENT! La machine utilisée de manière imprudente ou inadéquate peut devenir un outil dangereux, pouvant causer des blessures graves voire mortelles à l'utilisateur et aux autres personnes présentes.



Lire attentivement et bien assimiler le manuel d'utilisation avant d'utiliser la machine.



Utiliser des protecteurs d'oreilles



Toujours porter des lunettes de protection.



Utiliser un masque respiratoire.



AVERTISSEMENT! Ne procédez jamais à une découpe sans utiliser le protège-lame.



AVERTISSEMENT! Maintenir les mains et les pieds à distance de la lame.



**Marquage environnemental.** Ce symbole figurant sur le produit ou sur son emballage indique que ce produit ne peut pas être traité comme déchet ménager. Il doit être collecté et amené à une installation de récupération appropriée de déchets d'équipements électriques et électroniques.



En veillant à ce que ce produit soit correctement éliminé, vous pouvez contribuer à prévenir les conséquences négatives potentielles sur l'environnement et les hommes, qui pourraient sinon être le résultat d'un traitement incorrect des déchets de ce produit.

Pour des informations plus détaillées sur le recyclage de ce produit, contactez votre commune ou le magasin où vous avez acheté le produit.

Les autres symboles/autocollants présents sur la machine concernent des exigences de certification spécifiques à certains marchés.

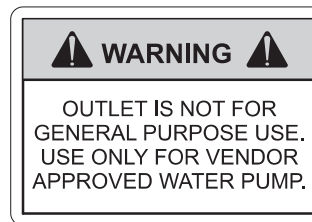
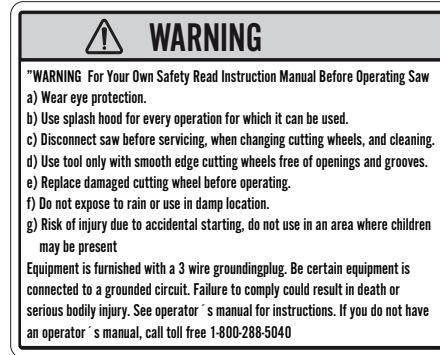

## Explication des niveaux d'avertissement

Il existe trois niveaux d'avertissement.

### AVERTISSEMENT!



**AVERTISSEMENT!** Symbole utilisé en cas de risque de blessures très graves ou de mort pour l'utilisateur ou de dommages pour les environs si les instructions du manuel ne sont pas suivies.

### REMARQUE !



**REMARQUE !** Symbole utilisé en cas de risque de blessures pour l'utilisateur ou de dommages pour les environs si les instructions du manuel ne sont pas suivies.

### ATTENTION !

**ATTENTION !** Symbole utilisé en cas de risque de dommages pour les matériaux ou la machine si les instructions du manuel ne sont pas suivies.